

**THREE-TERMINAL ADJUSTABLE  
OUTPUT POSITIVE VOLTAGE REGULATORS**

**Description**

The EP1017 are adjustable 3-terminal positive voltage regulators capable of supplying in excess of 1.5A over an output voltage range of 1.2 to 37V. These voltage regulators are exceptionally easy to use and require only two external resistors to set the output voltage. Further, they employ internal current limiting. Thermal shutdown and safe area compensation, making them essentially blow-out proof.

**Pin Assignment**

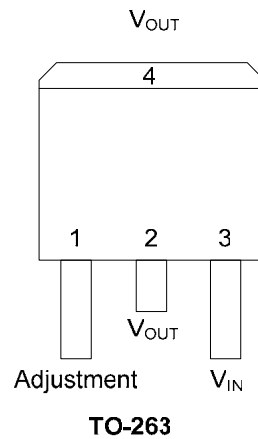
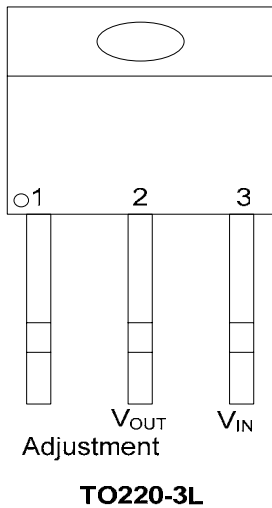

**Ordering Information**

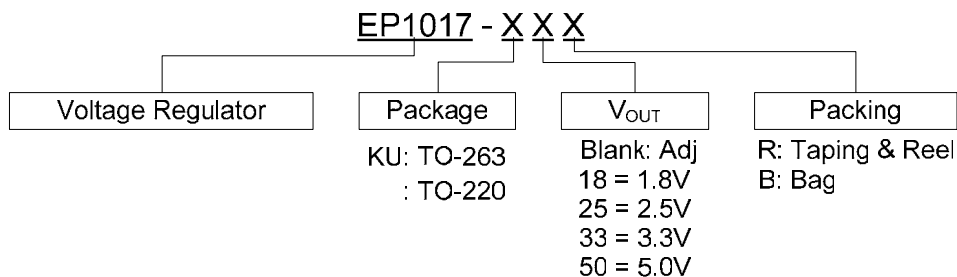

## Maximum Ratings

Rating	Symbol	Value	Unit
Input-Output Voltage Differential	$V_I-V_O$	40	Vdc
Power dissipation	$P_D$	Internally Limited	
Operating	T	-40 to +125	°C

## Electrical Characteristics ( $V_I-V_O=5.0V$ ; $I_O=0.5A$ ; $T_J=25^\circ C$ )

Symbol	Parameter	Conditions	Min.	Typ.	Max.	Units
$Reg_{line}$	Line Regulation <sup>1</sup>	$3.0V \leq (V_I-V_O) \leq 40V$			0.04	%/V
$Reg_{load}$	Line Regulation <sup>1</sup>	$10mA \leq I_{out} \leq 1.5A$ , $V_O \leq 5.0V, V_C \geq 5.0V$			25 0.5	mV %/V
$T_R$	Thermal Regulation	20ms Pulse			0.07	%/W
$I_{Adi}$	Adjustment Pin Current				100	μA
$V_{ref}$	Reference Voltage	<sup>2</sup> $P_D \leq 20W$ $3.0V \leq V_I-V_O \leq 40V$ $10mA \leq I_O \leq 1.5A$			1.3	V
$I_{LIMIT}$	Minimum Load Current to Maintain Regulation	$V_I-V_O=40V$			10	mA
$I_{Max}$	Maximum Output Current	$P_D \leq 20W, V_I-V_O \leq 15V$ $V_I-V_O=40V$	1.5 0.15	2.2 0.4		A
$\theta_{th}$	Thermal Resistance	junction to ambient		5.0		°C/W

### NOTES:

1. Load and line regulation are specified at constant junction temperature. Changes in  $V_O$  due to heating effects must be taken into account separately. Pulse testing with low duty cycle is used.
2. Selected devices with tightened tolerance reference voltage available.

Typical Performance Characteristics

Figure 5. Load Regulation

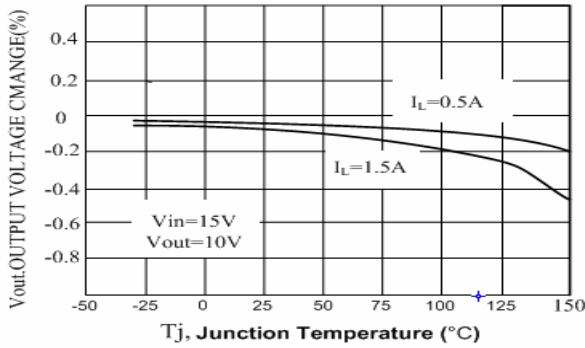

Figure 6. Current Limit

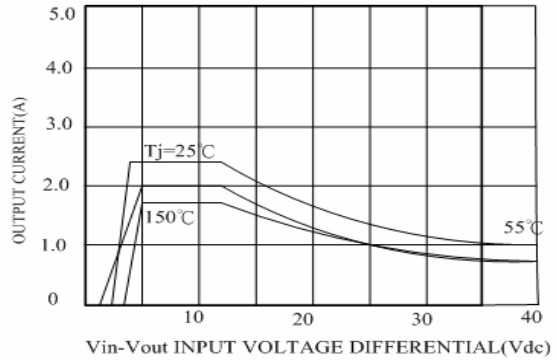

Figure 7. Adjustment Pin Current

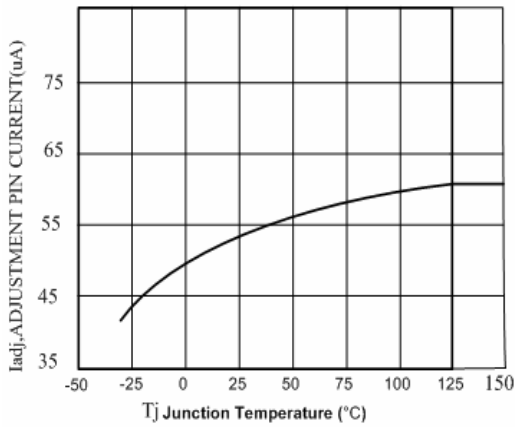

Figure 8. Dropout Voltage

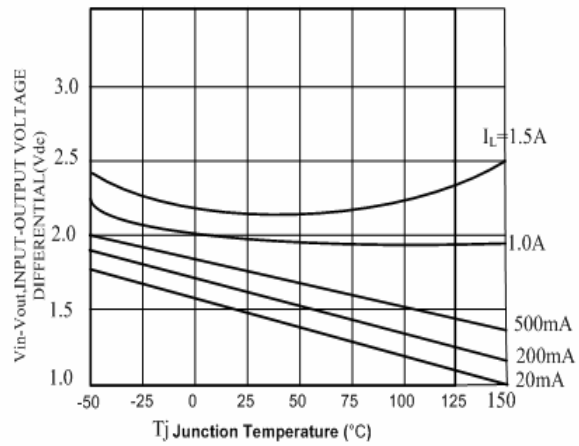

Figure 9. Temperature Stability

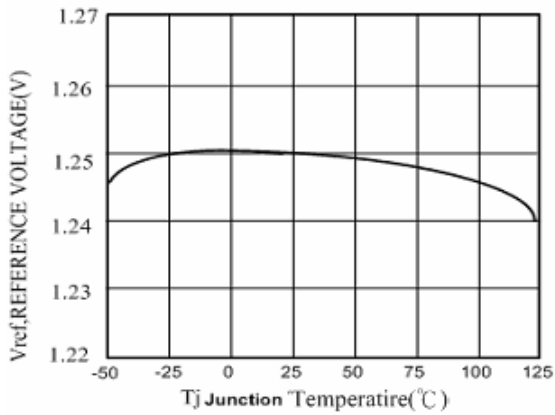

Figure 10. Minimum Operating Current

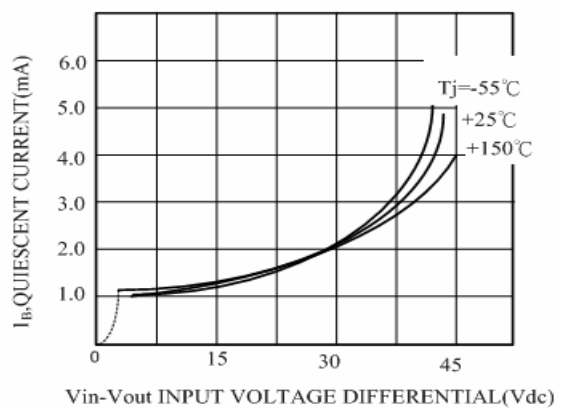

Figure 7. Ripple Rejection versus Output Voltage

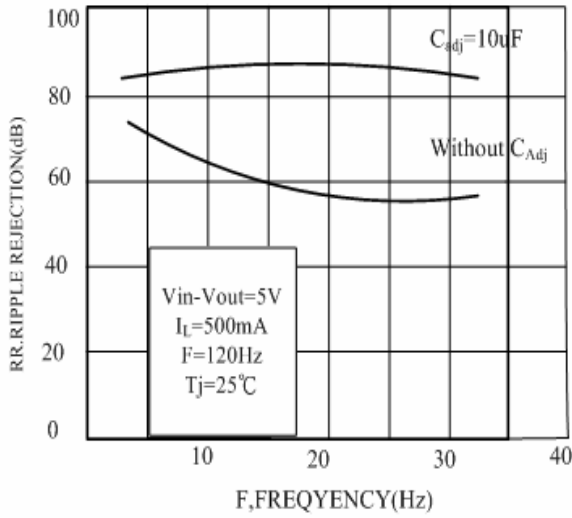

Figure 8. Ripple Rejection versus Output Current

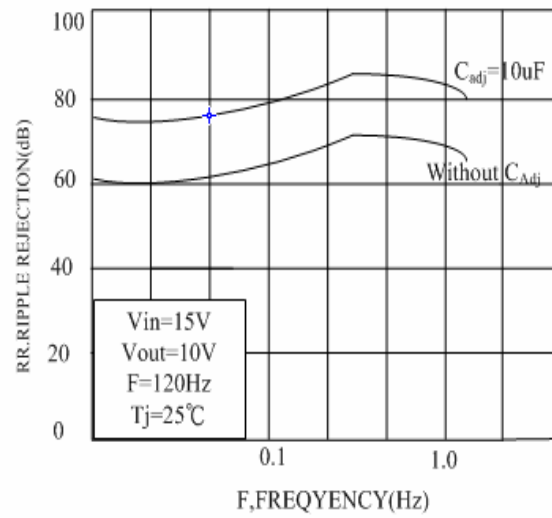

Figure 9. Ripple Rejection versus Frequency

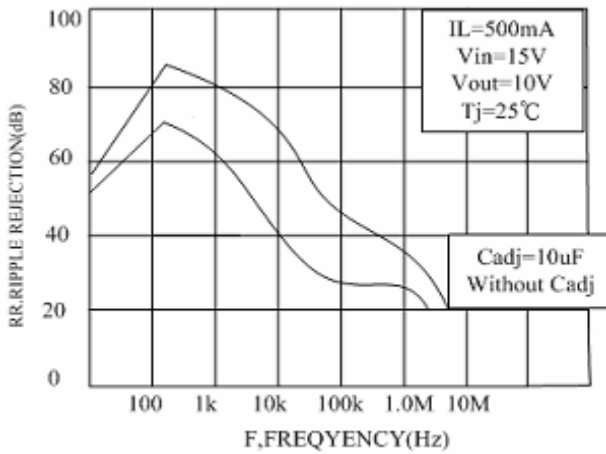

Figure 10. Output Impedance

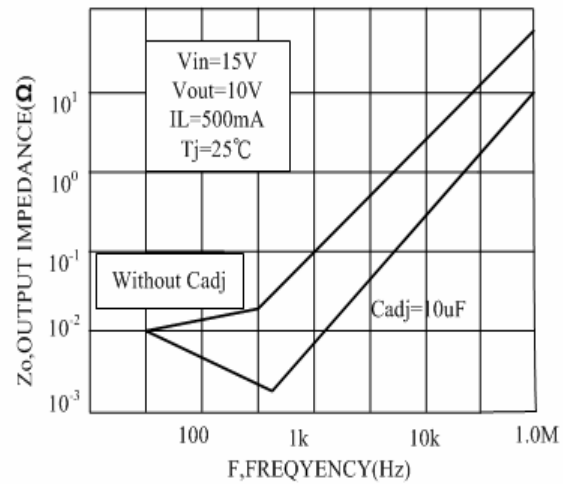

Figure 11. Line Transient Response

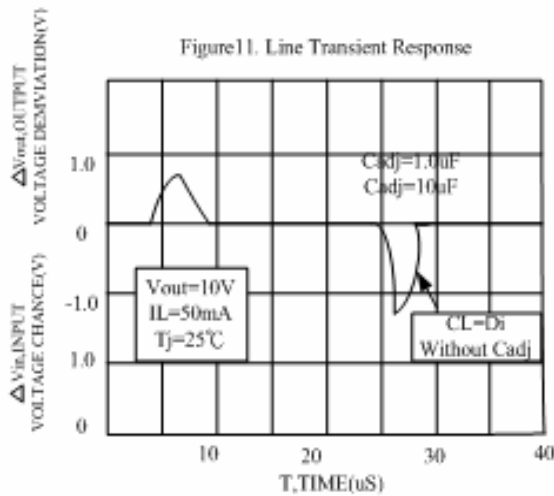
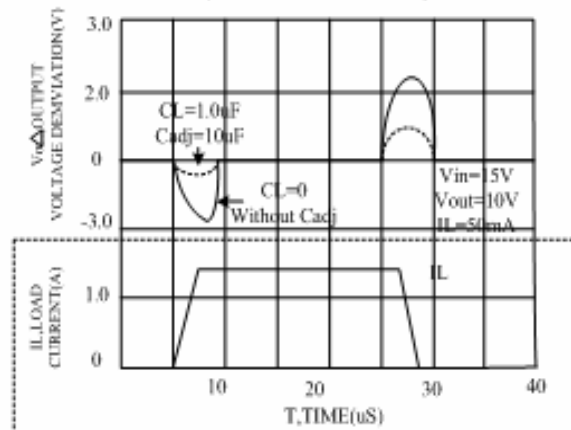
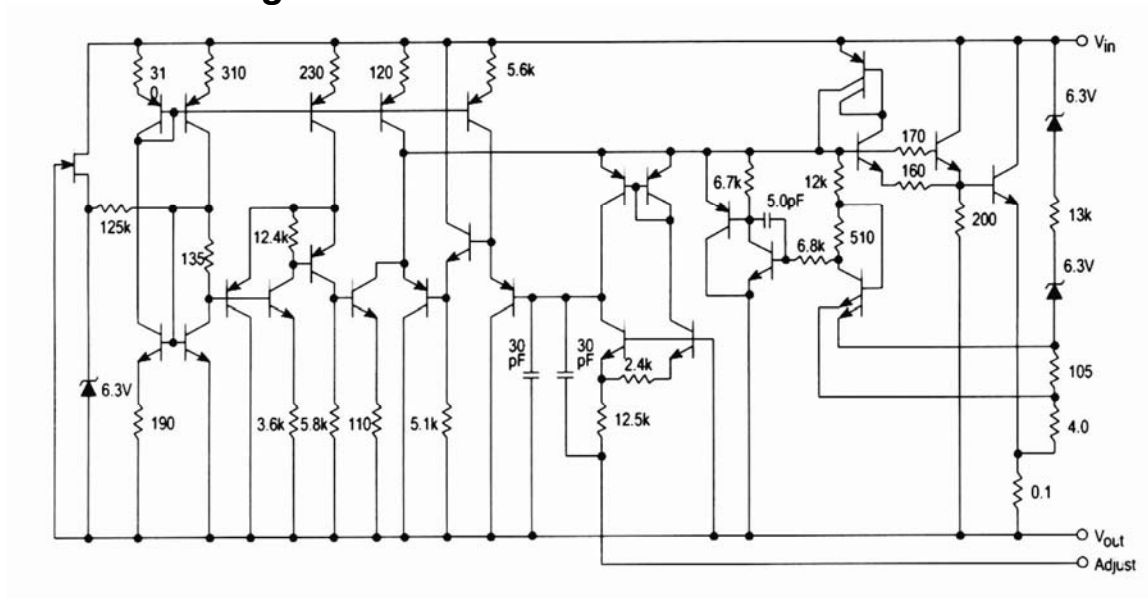

Figure 12. Load Transient Response



Schematic Diagram



EP1017 contains 29 active transistors

Typical Application

5.0V Electronic Shutdown Regulator

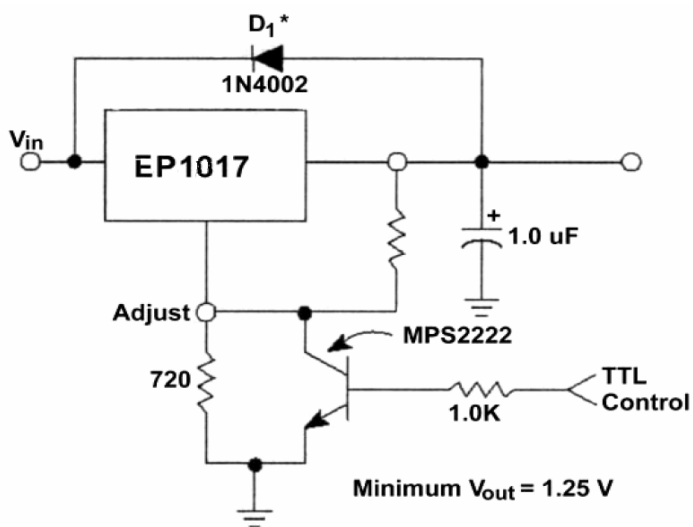

Standard Application

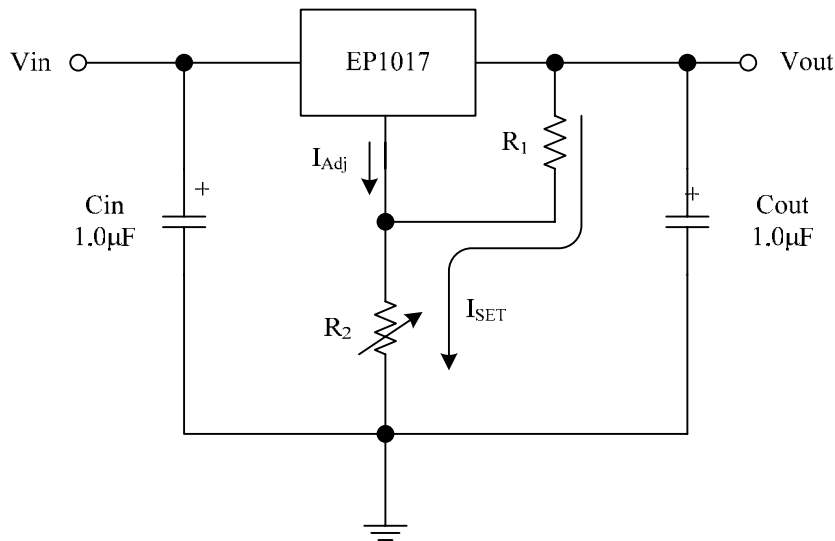

\* *Cin* is required if regulator is located an appreciable distance from power supply filter.

\* *Cout* is not needed for stability, however, it does improve transient response.

$$V_{out} = 1.25(1 + R_2/R_1) + I_{Adj}R_2$$

Since *IAdj* is controlled to less than 100 µA, the error associated with this term is negligible in most applications.

\* Pulse testing required. 1% Duty Cycle is suggested.

To calculate *R2*:  $V_{out} = I_{SET}R_2 + 1.250V$  ; Assume  $I_{SET} = 5.25mA$

Package Description

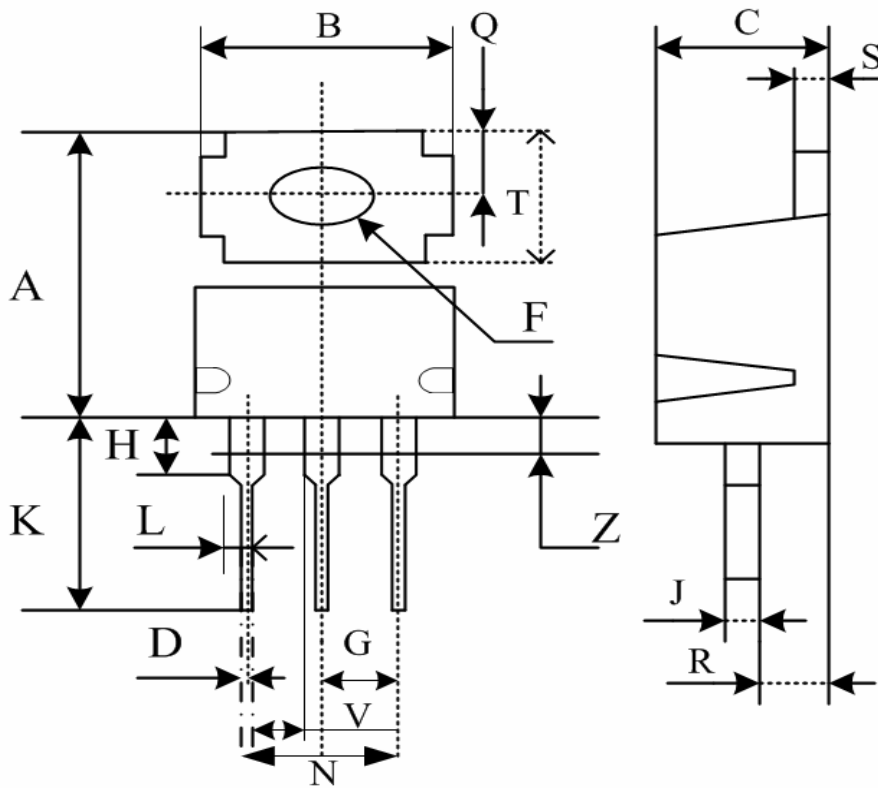

DIM	MILLIMETERS	
	MIN	MAX
A	14.97	16.24
B	9.66	10.28
C	4.07	4.82
D	0.64	0.88
F	3.61	3.73
G	2.42	2.66
H	2.80	3.93
J	0.48	0.67
K	12.70	14.27
L	1.20	1.63
N	4.83	5.33
Q	2.54	3.04
R	2.04	2.78
S	1.05	1.39
T	6.36	6.86
V	1.00	-
Z	-	2.04

Package Description (Continued)

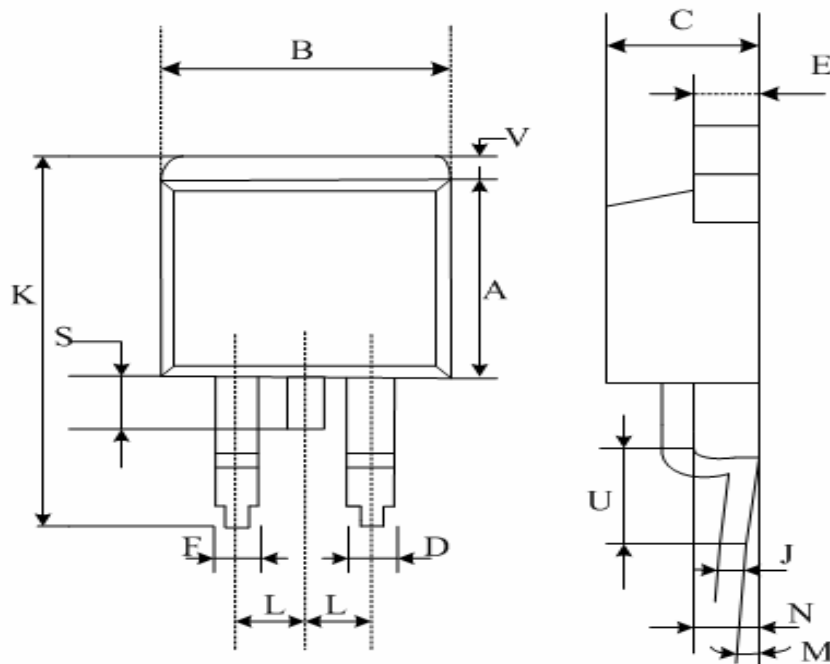

DIM	MILLIMETERS	
	MIN	MAX
A	8.64	9.65
B	9.65	10.29
C	4.06	4.83
D	0.51	0.99
E	1.14	1.40
F	1.14	1.40
J	0.46	0.74
K	14.61	15.88
L	2.54	
M	0°	8°
N	2.03	2.79
S	1.27	1.78
U	2.29	2.79
V	1.02	1.40